

# MC3425

## Power Supply Supervisory/ Over and Undervoltage Protection Circuit

The MC3425 is a power supply supervisory circuit containing all the necessary functions required to monitor over and undervoltage fault conditions. These integrated circuits contain dedicated over and undervoltage sensing channels with independently programmable time delays. The overvoltage channel has a high current Drive Output for use in conjunction with an external SCR Crowbar for shutdown. The undervoltage channel input comparator has hysteresis which is externally programmable, and an open-collector output for fault indication.

- Dedicated Over and Undervoltage Sensing
- Programmable Hysteresis of Undervoltage Comparator
- Internal 2.5 V Reference
- 300 mA Overvoltage Drive Output
- 30 mA Undervoltage Indicator Output
- Programmable Time Delays
- 4.5 V to 40 V Operation

### MAXIMUM RATINGS

Rating	Symbol	Value	Unit
Power Supply Voltage	$V_{CC}$	40	Vdc
Comparator Input Voltage Range (Note 1)	$V_{IR}$	-0.3 to +40	Vdc
Drive Output Short Circuit Current	$I_{OS(DRV)}$	Internally Limited	mA
Indicator Output Voltage	$V_{IND}$	0 to 40	Vdc
Indicator Output Sink Current	$I_{IND}$	30	mA
Power Dissipation and Thermal Characteristics	$P_D$	1000	mW
Maximum Power Dissipation @ $T_A = 70^\circ\text{C}$	$R_{\theta JA}$	80	$^\circ\text{C/W}$
Thermal Resistance, Junction-to-Air	$T_J$	+150	$^\circ\text{C}$
Operating Junction Temperature	$T_A$	0 to +70	$^\circ\text{C}$
Operating Ambient Temperature Range	$T_{stg}$	-55 to +150	$^\circ\text{C}$
Storage Temperature Range			

**NOTE:** 1. The input signal voltage should not be allowed to go negative by more than 300 mV or positive by more than 40 V, independent of  $V_{CC}$ , without device destruction.

### Simplified Application

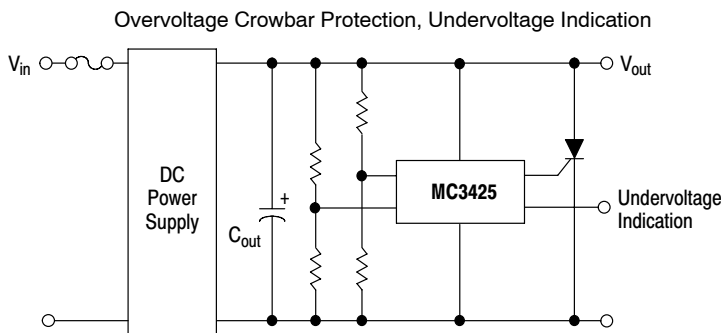

ON Semiconductor®

<http://onsemi.com>

## POWER SUPPLY SUPERVISORY/ OVER AND UNDERVOLTAGE PROTECTION CIRCUIT

### SEMICONDUCTOR TECHNICAL DATA

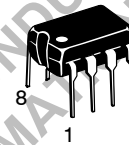

P1 SUFFIX  
PLASTIC PACKAGE  
CASE 626

### PIN CONNECTIONS

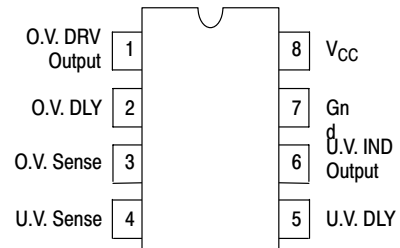

(Top View)

### ORDERING INFORMATION

Device	Operating Temperature Range	Package
MC3425P1	$T_A = 0^\circ$ to $+70^\circ\text{C}$	Plastic DIP

# MC3425

## ELECTRICAL CHARACTERISTICS (4.5 V ≤ V<sub>CC</sub> ≤ 40 V; T<sub>A</sub> = T<sub>low</sub> to T<sub>high</sub> [Note 2], unless otherwise noted.)

Characteristics	Symbol	Min	Typ	Max	Unit
<b>REFERENCE SECTION</b>					
Sense Trip Voltage (Referenced Voltage) V <sub>CC</sub> = 15 V T <sub>A</sub> = 25°C T <sub>low</sub> to T <sub>high</sub> (Note 2)	V <sub>Sense</sub>	2.4 2.33	2.5 2.5	2.6 2.63	Vdc
Line Regulation of V <sub>Sense</sub> 4.5 V ≤ V <sub>CC</sub> ≤ 40 V; T <sub>J</sub> = 25°C	Reg <sub>line</sub>	–	7.0	15	mV
Power Supply Voltage Operating Range	V <sub>CC</sub>	4.5	–	40	Vdc
Power Supply Current V <sub>CC</sub> = 40 V; T <sub>A</sub> = 25°C; No Output Loads O.V. Sense (Pin 3) = 0 V; U.V. Sense (Pin 4) = V <sub>CC</sub>	I <sub>CC(off)</sub>	–	8.5	10	mA
O.V. Sense (Pin 3) = V <sub>CC</sub> ; U.V. Sense (Pin 4) = 0 V	I <sub>CC(on)</sub>	–	16.5	19	mA
<b>INPUT SECTION</b>					
Input Bias Current, O.V. and U.V. Sense	I <sub>IB</sub>	–	1.0	2.0	μA
Hysteresis Activation Voltage, U.V. Sense V <sub>CC</sub> = 15 V; T <sub>A</sub> = 25°C; I <sub>H</sub> = 10% I <sub>H</sub> = 90%	V <sub>H(act)</sub>	– –	0.6 0.8	– –	V
Hysteresis Current, U.V. Sense V <sub>CC</sub> = 15 V; T <sub>A</sub> = 25°C; U.V. Sense (Pin 4) = 2.5 V	I <sub>H</sub>	9.0	12.5	16	μA
Delay Pin Voltage (I <sub>DLY</sub> = 0 mA) Low State High State	V <sub>OL(DLY)</sub> V <sub>OH(DLY)</sub>	– V <sub>CC</sub> –0.5	0.2 V <sub>CC</sub> –0.15	0.5 –	V
Delay Pin Source Current V <sub>CC</sub> = 15 V; V <sub>DLY</sub> = 0 V	I <sub>DLY(source)</sub>	140	200	260	μA
Delay Pin Sink Current V <sub>CC</sub> = 15 V; V <sub>DLY</sub> = 2.5 V	I <sub>DLY(sink)</sub>	1.8	3.0	–	mA
<b>OUTPUT SECTION</b>					
Drive Output Peak Current (T <sub>A</sub> = 25°C)	I <sub>DRV(peak)</sub>	200	300	–	mA
Drive Output Voltage I <sub>DRV</sub> = 100 mA; T <sub>A</sub> = 25°C	V <sub>OH(DRV)</sub>	V <sub>CC</sub> –2.5	V <sub>CC</sub> –2.0	–	V
Drive Output Leakage Current V <sub>DRV</sub> = 0 V	I <sub>DRV(leak)</sub>	–	15	200	nA
Drive Output Current Slew Rate (T <sub>A</sub> = 25°C)	di/dt	–	2.0	–	A/μs
Drive Output V <sub>CC</sub> Transient Rejection V <sub>CC</sub> = 0 V to 15 V at dV/dt = 200 V/μs; O.V. Sense (Pin 3) = 0 V; T <sub>A</sub> = 25°C	I <sub>DRV(trans)</sub>	–	1.0	–	mA (Peak)
Indicator Output Saturation Voltage I <sub>IND</sub> = 30 mA; T <sub>A</sub> = 25°C	V <sub>IND(sat)</sub>	–	560	800	mV
Indicator Output Leakage Current V <sub>OH(IND)</sub> = 40 V	I <sub>IND(leak)</sub>	–	25	200	nA
Output Comparator Threshold Voltage (Note 3)	V <sub>th(OC)</sub>	2.33	2.5	2.63	V
Propagation Delay Time (V <sub>CC</sub> = 15 V; T <sub>A</sub> = 25°C) Input to Drive Output or Indicator Output 100 mV Overdrive, C <sub>DLY</sub> = 0 μF	t <sub>PLH(IN/OUT)</sub>	–	1.7	–	μs
Input to Delay 2.5 V Overdrive (0 V to 5.0 V Step)	t <sub>PLH(IN/DLY)</sub>	–	700	–	ns

NOTES: 2. T<sub>low</sub> to T<sub>high</sub> = 0° to +70°C

3. The V<sub>th(OC)</sub> limits are approximately the V<sub>Sense</sub> limits over the applicable temperature range.

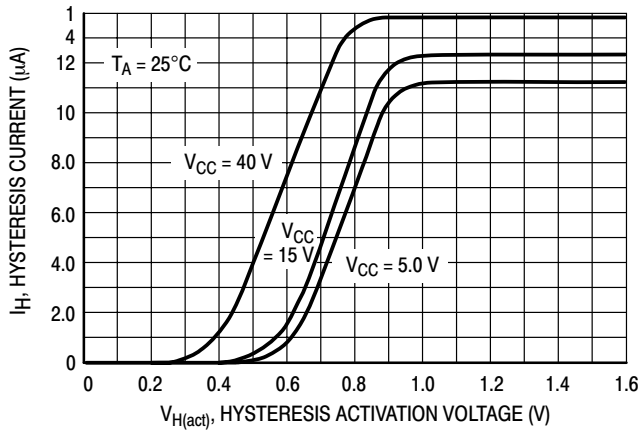

Figure 1. Hysteresis Current versus Hysteresis Activation Voltage

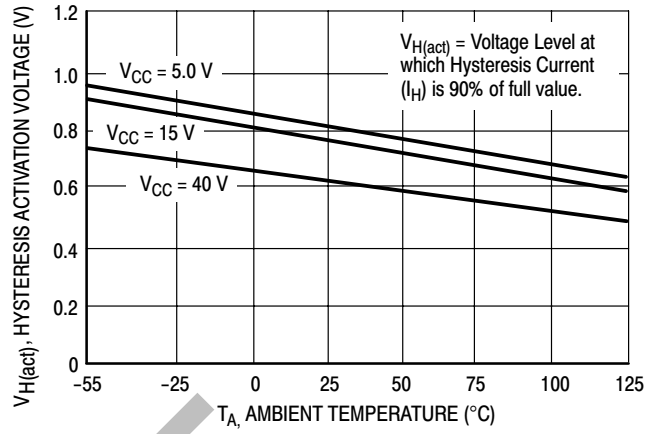

Figure 2. Hysteresis Activation Voltage versus Temperature

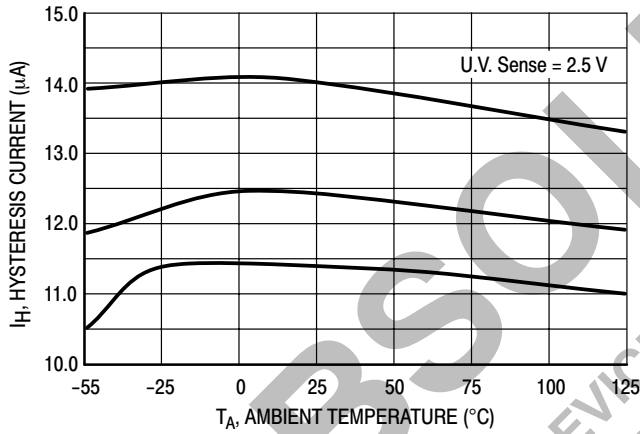

Figure 3. Hysteresis Current versus Temperature

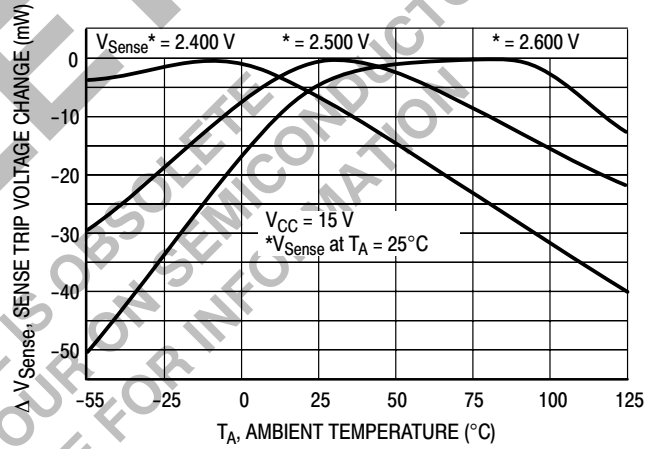

Figure 4. Sense Trip Voltage Change versus Temperature

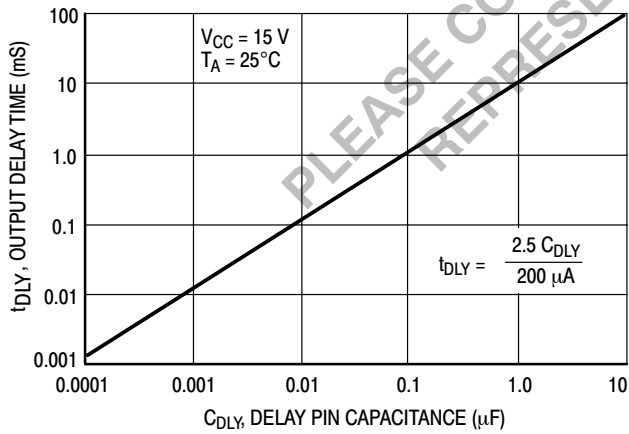

Figure 5. Output Delay Time versus Delay Capacitance

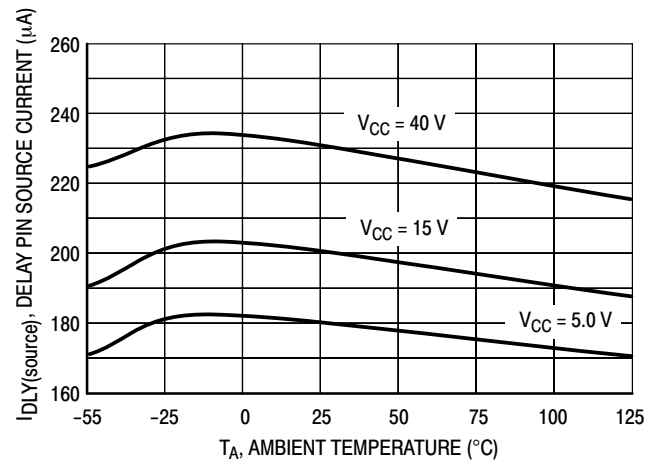

Figure 6. Delay Pin Source Current versus Temperature

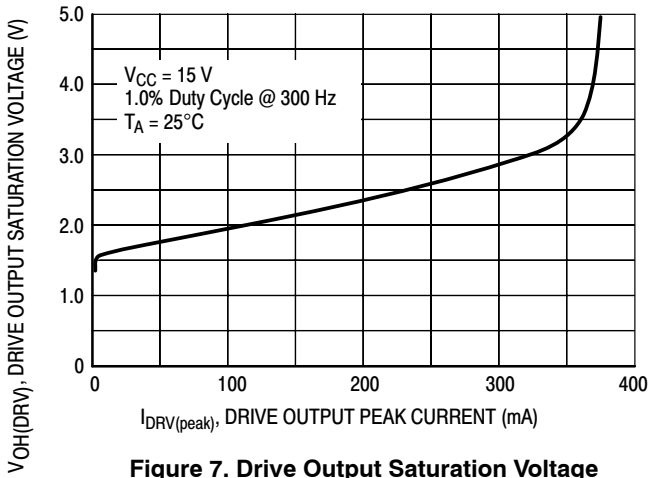

Figure 7. Drive Output Saturation Voltage versus Output Peak Current

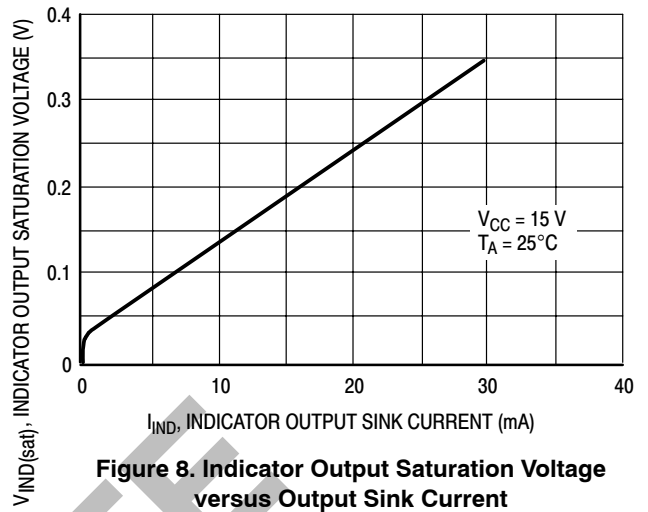

Figure 8. Indicator Output Saturation Voltage versus Output Sink Current

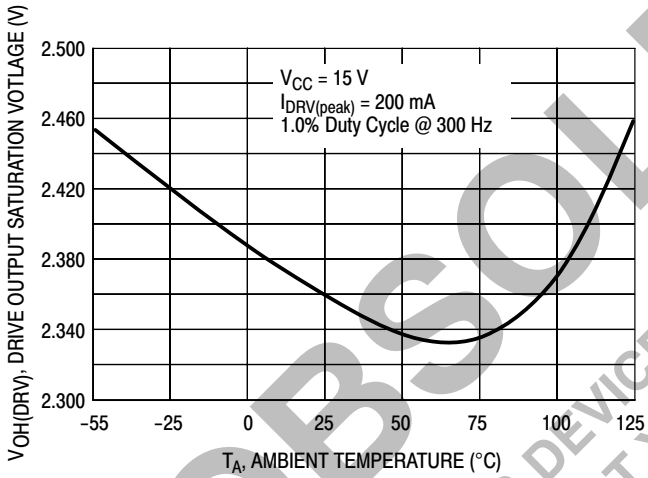

Figure 9. Drive Output Saturation Voltage versus Temperature

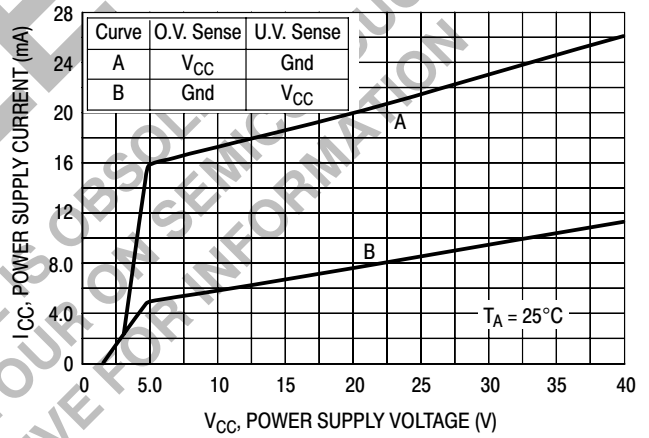
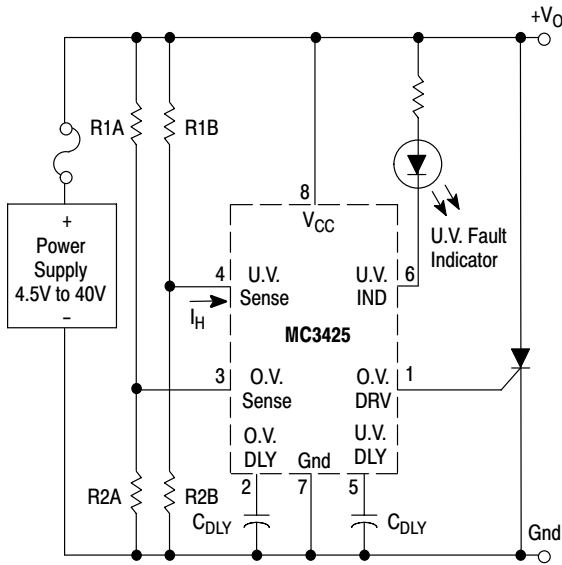

Figure 10. Power Supply Current versus Voltage

APPLICATIONS INFORMATION



$$U.V. \text{ Hysteresis} = I_H \left( \frac{R1B R2B}{R1B + R2B} \right), V_{O(trip)} - 2.5 V \left( 1 + \frac{R1A}{R2A} \right)$$

$$t_{DLY} = 12500 C_{DLY}$$

Figure 11. Overvoltage Protection and Undervoltage Fault Indication with Programmable Delay

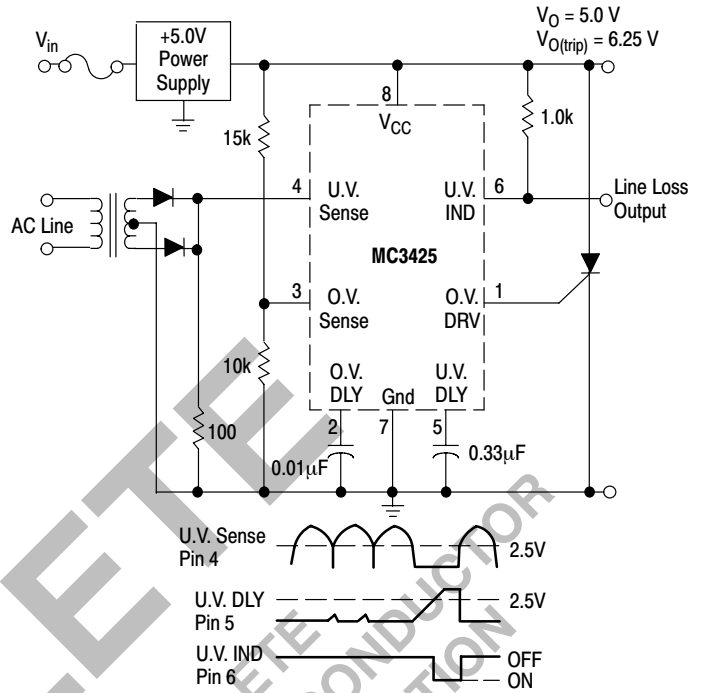

Figure 12. Overvoltage Protection of 5.0V Supply with Line Loss Detector

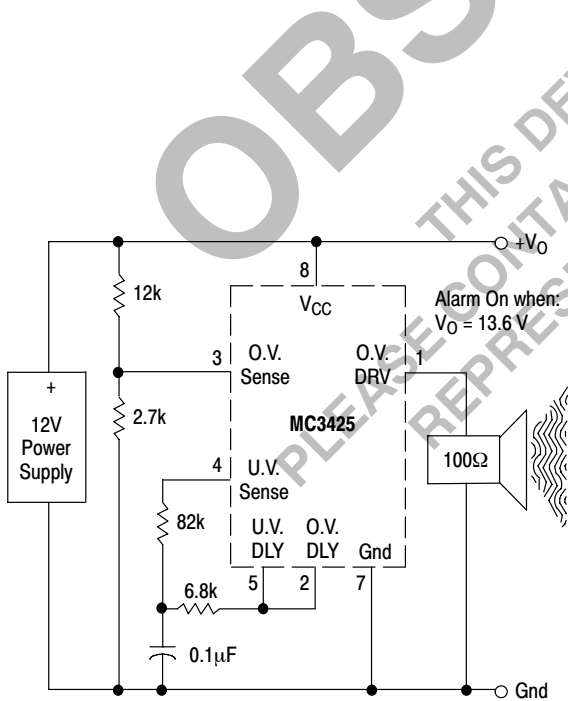

Figure 13. Overvoltage Audio Alarm Circuit

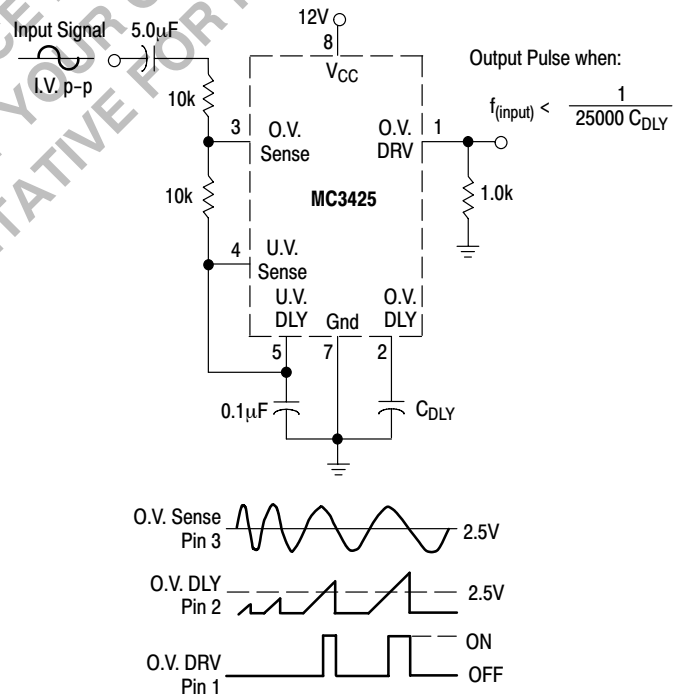

Figure 14. Programmable Frequency Switch

CIRCUIT DESCRIPTION

The MC3425 is a power supply supervisory circuit containing all the necessary functions required to monitor over and undervoltage fault conditions. The block diagram is shown below in Figure 15. The Overvoltage (O.V.) and Undervoltage (U.V.) Input Comparators are both referenced to an internal 2.5 V regulator. The U.V. Input Comparator has a feedback activated 12.5  $\mu$ A current sink ( $I_H$ ) which is used for programming the input hysteresis voltage ( $V_H$ ). The source resistance feeding this input ( $R_H$ ) determines the amount of hysteresis voltage by  $V_H = I_H R_H = 12.5 \times 10^{-6} R_H$ .

Separate Delay pins (O.V. DLY, U.V. DLY) are provided for each channel to independently delay the Drive and Indicator outputs, thus providing greater input noise immunity. The two Delay pins are essentially the outputs of the respective input comparators, and provide a constant current source,  $I_{DLY(source)}$ , of typically 200  $\mu$ A when the noninverting input voltage is greater than the inverting input level. A capacitor connected from these Delay pins to ground, will establish a predictable delay time ( $t_{DLY}$ ) for the Drive and Indicator outputs. The Delay pins are internally connected to the noninverting inputs of the O.V. and U.V. Output Comparators, which are referenced to the internal 2.5 V regulator. Therefore, delay time ( $t_{DLY}$ ) is based on the

constant current source,  $I_{DLY(source)}$ , charging the external delay capacitor ( $C_{DLY}$ ) to 2.5 V.

$$t_{DLY} = \frac{V_{ref} C_{DLY}}{I_{DLY(source)}} = \frac{2.5 C_{DLY}}{200 \mu A} = 12500 C_{DLY}$$

Figure 5 provides  $C_{DLY}$  values for a wide range of time delays. The Delay pins are pulled low when the respective input comparator's noninverting input is less than the inverting input. The sink current,  $I_{DLY(sink)}$ , capability of the Delay pins is  $\geq 1.8$  mA and is much greater than the typical 200  $\mu$ A source current, thus enabling a relatively fast delay capacitor discharge time.

The Overvoltage Drive Output is a current-limited emitter-follower capable of sourcing 300 mA at a turn-on slew rate at 2.0 A/ $\mu$ s, ideal for driving "Crowbar" SCR's. The Undervoltage Indicator Output is an open-collector, NPN transistor, capable of sinking 30 mA to provide sufficient drive for LED's, small relays or shut-down circuitry. These current capabilities apply to both channels operating simultaneously, providing device power dissipation limits are not exceeded.

The MC3425 has an internal 2.5 V bandgap reference regulator with an accuracy of  $\pm 4.0\%$  for the basic device.

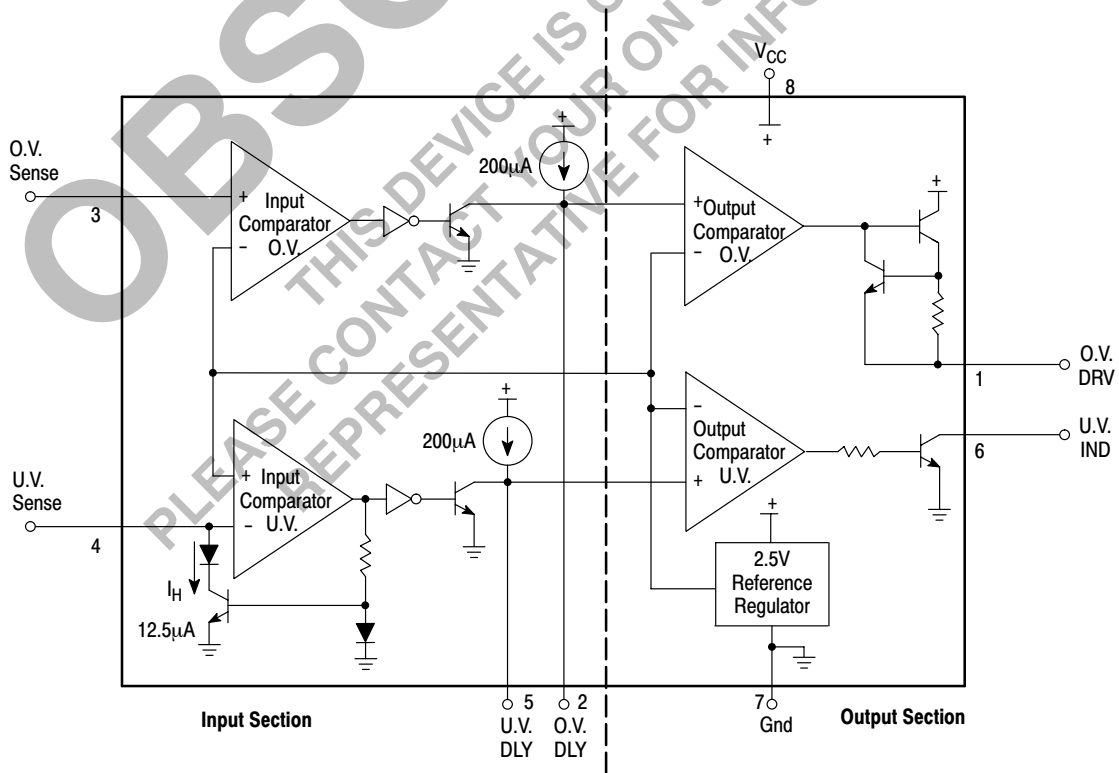

Note: All voltages and currents are nominal.

Figure 15. Representative Block Diagram

## CROWBAR SCR CONSIDERATIONS

Referring to Figure 16, it can be seen that the crowbar SCR, when activated, is subject to a large current surge from the output capacitance,  $C_{out}$ . This capacitance consists of the power supply output capacitors, the load's decoupling capacitors, and in the case of Figure 16A, the supply's input filter capacitors. This surge current is illustrated in Figure 17, and can cause SCR failure or degradation by any one of three mechanisms:  $di/dt$ , absolute peak surge, or  $I^2t$ . The interrelationship of these failure methods and the breadth of the applications make specification of the SCR by the semiconductor manufacturer difficult and expensive. Therefore, the designer must empirically determine the SCR and circuit elements which result in reliable and effective OVP operation. However, an understanding of the factors which influence the SCR's  $di/dt$  and surge capabilities simplifies this task.

1.  $di/dt$ 

As the gate region of the SCR is driven on, its area of conduction takes a finite amount of time to grow, starting as a very small region and gradually spreading. Since the anode current flows through this turned-on gate region, very high

current densities can occur in the gate region if high anode currents appear quickly ( $di/dt$ ). This can result in immediate destruction of the SCR or gradual degradation of its forward blocking voltage capabilities – depending on the severity of the occasion.

The value of  $di/dt$  that an SCR can safely handle is influenced by its construction and the characteristics of the gate drive signal. A center-gate-fire SCR has more  $di/dt$  capability than a corner-gate-fire type, and heavily overdriving (3 to 5 times  $I_{GT}$ ) the SCR gate with a fast  $< 1.0 \mu s$  rise time signal will maximize its  $di/dt$  capability. A typical maximum number in phase control SCRs of less than 50 A(RMS) rating might be 200 A/ $\mu s$ , assuming a gate current of five times  $I_{GT}$  and  $< 1.0 \mu s$  rise time. If having done this, a  $di/dt$  problem is seen to still exist, the designer can also decrease the  $di/dt$  of the current waveform by adding inductance in series with the SCR, as shown in Figure 18. Of course, this reduces the circuit's ability to rapidly reduce the dc bus voltage and a tradeoff must be made between speedy voltage reduction and  $di/dt$ .

(A) SCR Across Input of Regulator

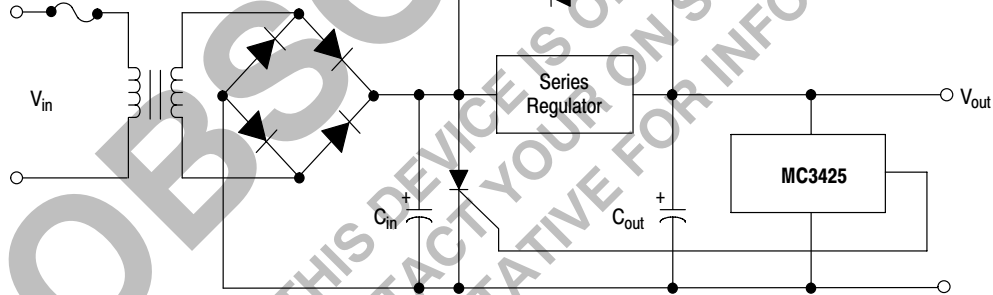

(B) SCR Across Output of Regulator

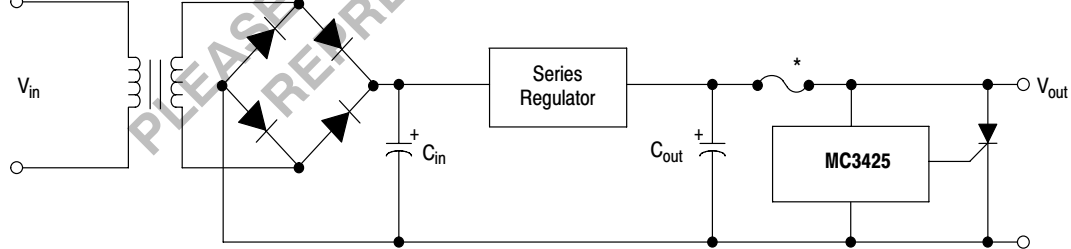

\*Needed if supply is not current limited.

Figure 16. Typical Crowbar Circuit Configurations

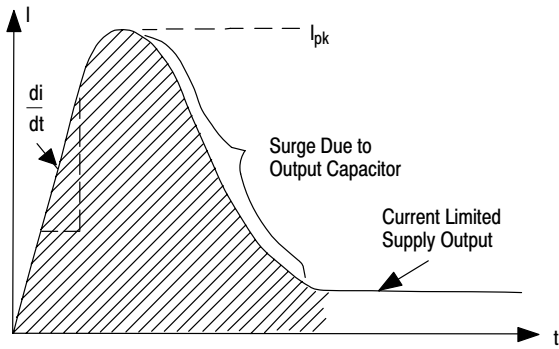

Figure 17. Crowbar SCR Surge Current Waveform

**2. Surge Current**

If the peak current and/or the duration of the surge is excessive, immediate destruction due to device overheating will result. The surge capability of the SCR is directly proportional to its die area. If the surge current cannot be reduced (by adding series resistance – see Figure 18) to a safe level which is consistent with the system’s requirements for speedy bus voltage reduction, the designer must use a higher current SCR. This may result in the average current capability of the SCR exceeding the steady state current requirements imposed by the DC power supply.

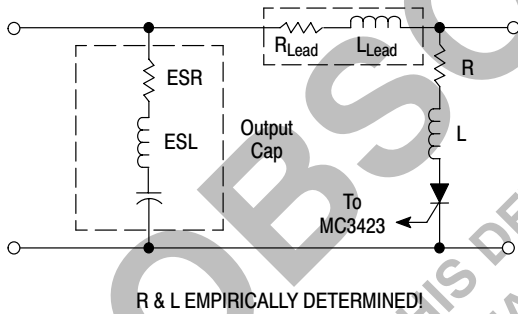

Figure 18. Circuit Elements Affecting SCR Surge & di/dt

**UNDERVOLTAGE SENSING**

An undervoltage sense circuit with hysteresis may be designed, as shown in Figure 11, using the following equations:

$$R1 = \frac{V_{CCU} - V_{CC1}}{12.5 \mu A}$$

$$R2 = \frac{2.5 R1}{V_{CC1} - 2.5}$$

where:  $V_{CCU}$  is the designed upper trip point (output indicator goes off)  
 $V_{CC1}$  is the lower trip point (output indicator goes on)

**A WORD ABOUT FUSING**

Before leaving the subject of the crowbar SCR, a few words about fuse protection are in order. Referring back to Figure 16A, it will be seen that a fuse is necessary if the power supply to be protected is not output current limited. This fuse is not meant to prevent SCR failure but rather to prevent a fire!

In order to protect the SCR, the fuse would have to possess an  $I^2t$  rating less than that of the SCR and yet have a high enough continuous current rating to survive normal supply output currents. In addition, it must be capable of successfully clearing the high short circuit currents from the supply. Such a fuse as this is quite expensive, and may not even be available.

The usual design compromise then is to use a garden variety fuse (3AG or 3AB style) which cannot be relied on to blow before the thyristor does, and trust that if the SCR does fail, it will fail short circuit. In the majority of the designs, this will be the case, though this is difficult to guarantee. Of course, a sufficiently high surge will cause an open. These comments also apply to the fuse in Figure 16B.

**CROWBAR SCR SELECTION GUIDE**

As an aid in selecting an SCR for crowbar use, the following selection guide is presented.

Device	$I_{RMS}$	$I_{TSM}$
MCR310 Series	10 A	100 A
MCR16 Series	16 A	150 A
MCR25 Series	25 A	300 A
2N6501 Series	25 A	300 A
MCR69 Series	25 A	750 A
MCR264 Series	40 A	400 A
MCR265 Series	55 A	550 A



# MC3425

## PACKAGE DIMENSIONS

P1 SUFFIX  
PLASTIC PACKAGE  
CASE 626-05  
ISSUE L

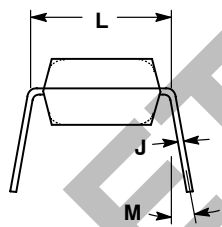
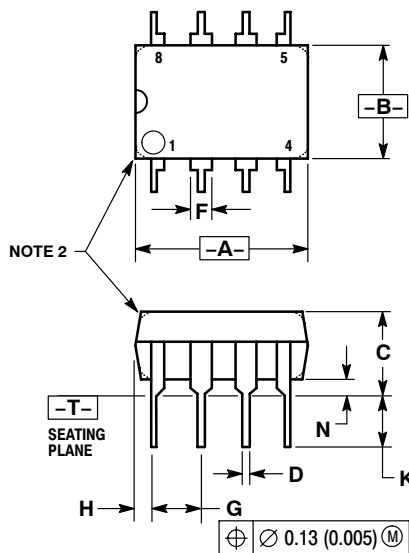

### NOTES:

1. DIMENSION L TO CENTER OF LEAD WHEN FORMED PARALLEL.
2. PACKAGE CONTOUR OPTIONAL (ROUND OR SQUARE CORNERS).
3. DIMENSIONING AND TOLERANCING PER ANSI Y14.5M, 1982.

DIM	MILLIMETERS		INCHES	
	MIN	MAX	MIN	MAX
A	9.40	10.16	0.370	0.400
B	6.10	6.60	0.240	0.260
C	3.94	4.45	0.155	0.175
D	0.38	0.51	0.015	0.020
F	1.02	1.78	0.040	0.070
G	2.54 BSC		0.100 BSC	
H	0.76	1.27	0.030	0.050
J	0.20	0.30	0.008	0.012
K	2.92	3.43	0.115	0.135
L	7.62 BSC		0.300 BSC	
M	---	10 <sup>°</sup>	---	10 <sup>°</sup>
N	0.76	1.01	0.030	0.040

ON Semiconductor and are registered trademarks of Semiconductor Components Industries, LLC (SCILLC). SCILLC reserves the right to make changes without further notice to any products herein. SCILLC makes no warranty, representation or guarantee regarding the suitability of its products for any particular purpose, nor does SCILLC assume any liability arising out of the application or use of any product or circuit, and specifically disclaims any and all liability, including without limitation special, consequential or incidental damages. "Typical" parameters which may be provided in SCILLC data sheets and/or specifications can and do vary in different applications and actual performance may vary over time. All operating parameters, including "Typicals" must be validated for each customer application by customer's technical experts. SCILLC does not convey any license under its patent rights nor the rights of others. SCILLC products are not designed, intended, or authorized for use as components in systems intended for surgical implant into the body, or other applications intended to support or sustain life, or for any other application in which the failure of the SCILLC product could create a situation where personal injury or death may occur. Should Buyer purchase or use SCILLC products for any such unintended or unauthorized application, Buyer shall indemnify and hold SCILLC and its officers, employees, subsidiaries, affiliates, and distributors harmless against all claims, costs, damages, and expenses, and reasonable attorney fees arising out of, directly or indirectly, any claim of personal injury or death associated with such unintended or unauthorized use, even if such claim alleges that SCILLC was negligent regarding the design or manufacture of the part. SCILLC is an Equal Opportunity/Affirmative Action Employer. This literature is subject to all applicable copyright laws and is not for resale in any manner.

### PUBLICATION ORDERING INFORMATION

#### LITERATURE FULFILLMENT:

Literature Distribution Center for ON Semiconductor  
P.O. Box 5163, Denver, Colorado 80217 USA  
Phone: 303-675-2175 or 800-344-3860 Toll Free USA/Canada  
Fax: 303-675-2176 or 800-344-3867 Toll Free USA/Canada  
Email: orderlit@onsemi.com

N. American Technical Support: 800-282-9855 Toll Free  
USA/Canada  
Europe, Middle East and Africa Technical Support:  
Phone: 421 33 790 2910  
Japan Customer Focus Center  
Phone: 81-3-5773-3850

ON Semiconductor Website: [www.onsemi.com](http://www.onsemi.com)

Order Literature: <http://www.onsemi.com/orderlit>

For additional information, please contact your local Sales Representative